

KEY MACHINES

SECTION 8

KEY MACHINES

Index

B

Brushes 28

D

Deburring 28

E

Engraver 2, 3

K

Key Cutters 10, 12, 14, 17, 25, 27, 29, 30

Key Shop Stamps 2

M

Manual Duplicator 22

P

Parts 14, 25, 28, 29, 30

Punch Machines 15, 26

T

Tubular Key Machines 4, 7, 9, 13, 24

V

Vendors

A-1	4
BIANCHI	4- 6
FRAMON	7, 8
HATA	8
HPC	2, 9-16, 30
ILCO	2, 3, 17-26, 28, 30
PRO-LOCK	26
RYTAN	27- 28
YOUNG BROS	2

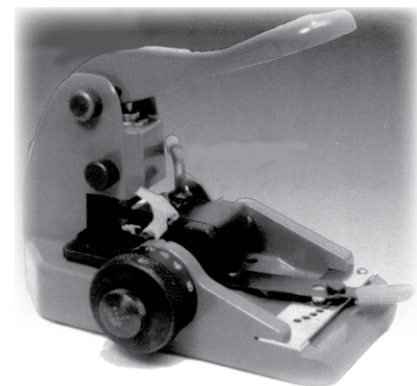

HPC Stamp Aligner™

The Stamp Aligner™ holds the stamps so that figures may be stamped on keys in an exact straight line with exact spacing between characters.

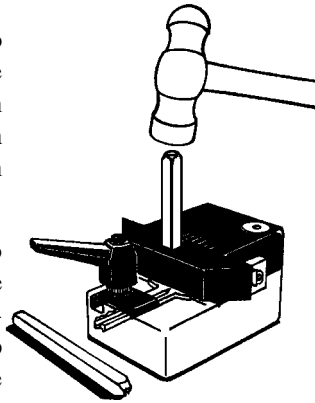

A key is placed onto the bottom part of the Stamp Aligner and secured in place. The top part is moved into one of the spacing indexes.

The stamp is placed into the square hole over the spot where the key is to be stamped. The stamp is held exactly in place for it to be struck by a hammer. Spacing is clearly defined by a spring loaded detent built into the device. Each character stamped on the key will be straight, spaced evenly, and aligned perfectly. When the stamps are all struck with the same force, the result is a key that looks like it was factory stamped. (Hammer not included.)

SA-7 1/4" square hole fits 3/32" and 1/8" number and letter die stamps (stamps not included).

Order #	Item #	Price
360-2341	HPC SA-7	\$353.00

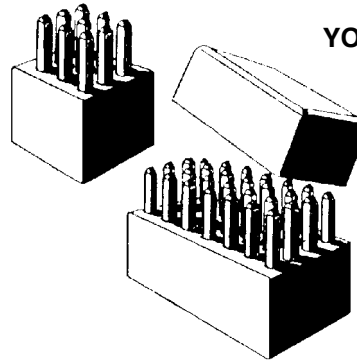

YOUNG BROS STAMP WORKS

Machine Made Letter & Figure Sets.

Letter Sets (27 Characters): \$76.24 set

Order #	Item #	Size
980-1332	YOU-3/32L	3/32"
980-1018	YOU-1/8L	1/8"

Figure Sets (9 Characters): \$25.42 set

Order #	Item #	Size
980-0332	YOU-3/32F	3/32"
980-0018	YOU-1/8F	1/8"

Key Shop Stamps

Stock imprints needed by key shops and security personnel everywhere.

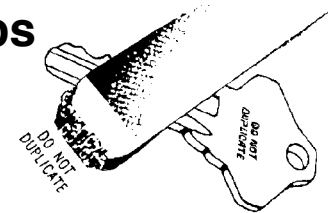

Order #	Item #	Stamp	Cat.Price
280-0102	EVE-102	MASTER	\$79.90
280-0105	EVE-105	DO NOT DUPLICATE	66.08

ILCO Marker 2000 engraves keys, cylinders, medals and plaques!



Drop Ship Item.

Quick & easy to use. Engrave any type of metal including nickel silver, brass and steel. Machine can be used to personalize various objects such as keys, cylinders and

plaques. Use your own IBM compatible keyboard with the MARKER 2000, or attach your PC and run it using Silca's software for Windows. Liquid crystal display, illuminated from behind and positioned in the upper part of the machine to ensure excellent visibility for the operator. A special patented laser system ensures rapid and precise location of the marking zones, which can be updated by means of the tracking disk. A wide choice of characters, fonts, and graphics are contained in the mine.

Specifications

Size: 8.66"W x 12.6"D x 17.72"H **Marker:** x axis: 1.97", Y axis: 1.38"

Punch: Interchangeable, in super rapid tempered steel alloy.

Maximum Punch Frequency: 80 punches per second

Movements: on two axes; C1 Standard Clamp

Display: 20 characters, 4 lines, illuminated from behind.

Keyboard: Standard IBM compatible - NOT SUPPLIED - (mini din 6 pole socket)

Power: 110V - 60Hz - 90 Watt - 0.6A

Order #	Item #	Price
400-2000	Marker 2000 Engraver	\$11,688.00



ILCO Marking Equipment



ENGRAVE-IT™

Engrave-It is the perfect complement to key duplication services. An Engraver Keys, Pet Tags, Luggage Tags, ID Tags and Collar Tags.

It is compact, lightweight and requires virtually no training. Features quiet operation, built-in counter for control purposes, and easily fits on countertops.

A great add-on sale to help customers ID their keys and eliminate confusion. It only takes a few minutes to earn extra profits.

- Engraves brass, nickel plate and nickel silver Keys, Pet Tags and ID tags.
- Selection of type fonts produce great looking engraving
- A selection of miscellaneous designs is also included in the program.
- Engraved text automatically adjusts to fill tag size.
- Capable of engraving both sides.
- Three Holders (pet tags, keys, misc.) are included.
- Compact; easily fits on most countertops.
- Quiet operation.
- Large tilting, high resolution, graphical screen.
- Built in tag counter for control purposes.
- Simple to operate, virtually no training required.
- Future updates are easy; memory card media
- Point-of purchase materials included
- Engraves KW1, SC1, M1, Y1, AR4, WR5, neuter bow, hotel key, and Best/Falcon.

Package Includes:

Keyboard, 3 holders, instruction manual, template book (for consumer), 300 assorted pet tags (approx.. \$2,100 resell value), acrylic display with engraved tags attached, two window decals, two shelf talkers.

Specifications:

13.5"W x 16.25"D x 14.5" H. Weight: 48 lbs.

Order #	Item #	Catalog Price
400-8000	Engrave-It	\$9750.00



One Machine Does It All!

Increase Your Profits Engraving Keys



Increase Your Profits Engraving Pet Tags



A-1/BIANCHI

A-1



Mfg. Corp.

HERTY GERTY HG-1

Now you can duplicate tubular keys without a large outlay of cash. In seconds, this unique machine will code cut #137 tubular keys - standard, large, small, right and left. Ace, Gem, Ilco, etc. Pin in a pin and any spacing from 0 to 360°. Comes complete with decoder, special carbide cutters, wood case, and instructions. Tubular Key Machines

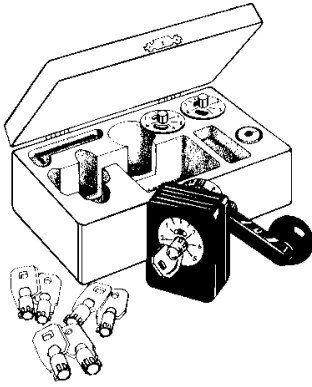

Order #	Item #	PRICE
005-0115	HG-1	\$731.50

KEY MACHINES

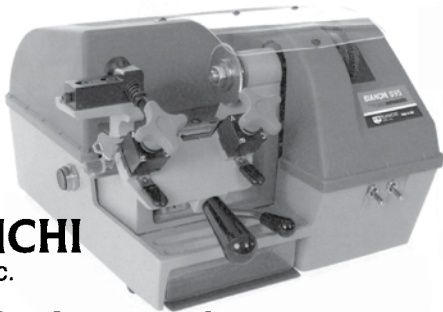

BIANCHI
Since 1770 USA, Inc.

Bianchi 095 Automatic

- Automatic operation with a safety start feature; uses two momentary push buttons for start-up
- Four-way reversible jaws securely clamp residential, commercial, padlock, and automotive keys including double sided versions.
- Automatic cutter shut-off for safety
- Heavy-duty cast aluminum body dramatically reduces vibration & noise improving both cut consistency & cutter life
- Equipped with a carriage stop which prevents jaws from accidentally contacting the cutter
- Micrometric tracer adjustment features a dual axis gauging system for quick, easy, and accurate depth calibration; especially useful for worn keys
- Smooth and accurate carriage movements are guaranteed by machine slide-ways in the casting
- Independent brush button operates soft-touch deburring brush
- 1/4 hp, 1800 rpm motor

Wt: 39 lbs. 10" High, 15" Wide, 18" Deep

Order #	Item #	Catalog Price
132-0095	B095	\$2598.00

BIANCHI

KEY MACHINES

BIANCHI
Since 1770 USA, Inc.



Bianchi 106 Semi-Automatic

- Microswitch activation with improved spring loaded carriage design, ergonomic handles and smooth balanced operation
- Unique one-piece jaw alignment system features a locking mechanism preventing accidental carriage release
- Four-way reversible jaws securely clamp residential, commercial, padlock, and automotive keys including single and double sided versions
- Heavy-duty cast aluminum body dramatically reduces vibration and noise improving both cut consistency and cutter life
- Micrometric tracer adjustment for quick, easy, and accurate depth calibration
- Updated design features ergonomic handles and levers, removable chip tray and upper storage tray
- Large transparent cutter shield and offset carriage improve viewing during cutting
- Independent brush button for soft-touch deburring brush
- Overhead neon light with drop-down magnifying glass illuminates key cutting area
- 1/4 hp, 1680 rpm motor

Wt: 55 lbs, 17" high, 18" wide, and 15" deep

Order #	Item #	Catalog Price
132-0106	B106	\$3350.00



303 High Security Duplicator

- Duplicates high security laser and dimple type keys
- Microswitch activated cutter start with vertical and lateral carriage locking system to ease the cutting process

- One-piece cast iron body reduces vibration and noise improving both cut consistency and cutter life
- Dual mode system: red button calibrates, black button cuts
- Large, full view coverage shield for improved visibility and reduction of key shaving dispersal
- Three dimensional calibration results in greater cut accuracy; machine beeps when calibrated correctly
- Electronic height adjustment with directional indicator
- Removable faceplates
- Long-lasting and bright LED style light
- Includes Audi/VW adapters at no additional charge
- 200 watt, 7000 rpm motor
- Weight: 51 lbs. 21" high, 12" wide, and 15" deep
- Cutter and Tracer: 2.5 & 3mm diameter high speed steel

Order #	Item #	Catalog Price
132-0303	B303	\$4478.00

304 High Security Duplicator

same technology as the Bianchi 303 but with the added feature of precise tilting jaws. If you already own the 303, you can easily upgrade to the 304 simply by special ordering the 304 jaw assembly.

Order #	Item #	Catalog Price
132-0304	B304	\$5200.00



102 Semi-Automatic Duplicator

- Microswitch activation with release of spring loaded locking carriage
- Four-way reversible jaws securely clamp residential, commercial, padlock, and automotive keys including single and double sided versions
- Heavy duty cast iron body dramatically reduces vibration and noise improving both cut consistency and cutter life
- Wide jaw spacing accommodates longer and larger headed keys
- Large transparent cutter shield and offset carriage improve viewing during cutting
- Micrometric tracer adjustment for quick, easy, and accurate depth and spacing calibration
- Independent large red brush operates soft-touch deburring brush
- 1/4 hp, 1680 rpm motor
- Wt: 57 lbs. 10" high, 16" wide, and 13" deep
- Cutter 80mm high speed

Order #	Item #	Catalog Price
132-0102	B102-4	\$2490.00

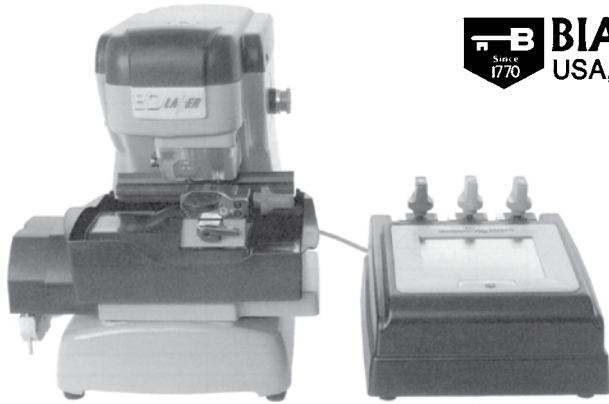

B994
The Most Advanced
Code Cutting Machine in the Market

- Cuts by code, decode or depths and duplicates high security keys
- Complete database of high security systems to be cut built-in; no computers needed
- Easily updated with SmartMedia technology
- Key information is automatically converted to original lock specification when duplicating
- Includes A & C jaws to cut most popular high security laser keys
- Electronic calibration

Specifications: • Weight: 50 lbs
 • Cutter Motor: One speed, single phase
 • Power: 110v/60Hz
 • Tolerances: X-Y axis +/- .001"
 Machine: 14" length, 12" wide, 14" high
 Console: 10" length, 9" wide, 5" high

Order #	Item #	Catalog Price
132-0994	B994	\$17,990.00

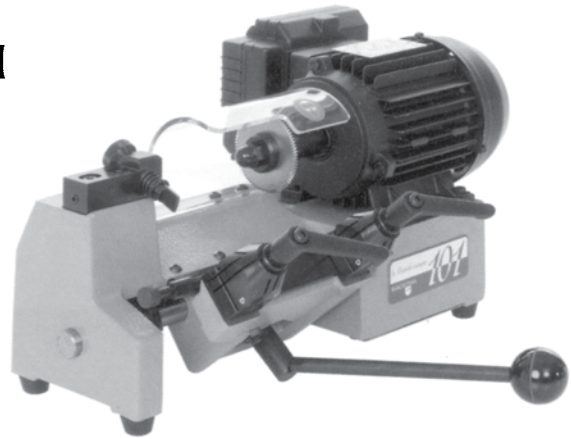

Manual Duplicator

- Four-way reversible jaws securely clamp residential, commercial, padlock, and automotive key including single and double sided versions.
- Offset carriage for improved feel and view during operation
- "L" style jaw handles make key gripping easy and hard alloy handles reduce both inner and outer part wear
- jaws rest directly on jaw pin for improved tolerance
- Manual operation with lateral carriage lever easing the cutting process
- Wide jaw spacing accommodates longer and larger headed keys
- Small footprint, 11" high, 17" wide, & 10" deep
- Quick, easy, and precise machine calibration; micrometric depth adjustment
- 1/4 hp, 1680 rpm motor; • Wt. 37 lbs
- Cutter: 63mm high speed steel

Order #	Item #	Catalog Price
132-0101	B101-4	\$1598.00



KEY MACHINES

Framon

FRA-2 Code Machine

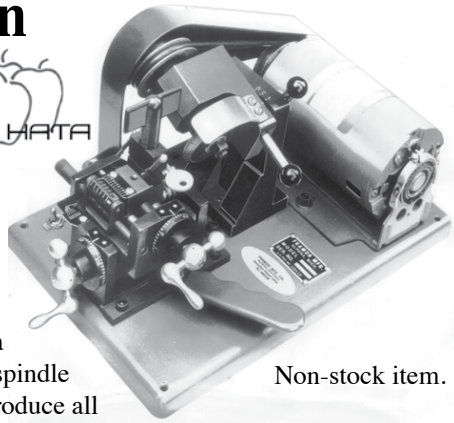

Non-stock item.

Equipped with a standard, fixed spindle head and will produce all standard cylinder and flat keys.

Cuts code keys, original keys or first keys for rekeying or combination changes. Rugged enough to endure being bounced around a mobile unit without needing readjustments.

All plates and cards are built into the machine.

With tilting spindle head required for cutting Medeco and Emhart keys (Cutter included). Also cuts regular cylinder keys.

Order #	Item #	Catalog Price
315-0002	FRA-2	\$4590.00

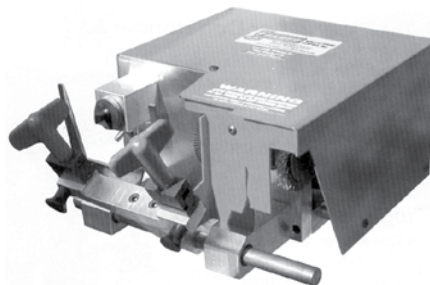

Dimensions:
12" W x 15" D x 6" H
Weight: 29 lbs.

MD-1 Manual Duplicator Machine

Manual duplicator designed for locksmiths, automotive dealerships, and hardware stores to cut a wide variety of keys without the need of additional accessories.

- Cut almost any cylinder key in use today.
- Accepts keys up to 4" in length
- Wire deburring brush included
- Reversible vises hold a wide variety of keys without tipping
- Flip-down key stop for aligning shoulders or tips of keys
- Carriage wipers to keep chips off of yoke rod
- Sealed ball bearings in spindle assembly
- Adjustable guide (.001" increments)

Order #	Item #	Catalog Price
315-0015	(U) MD-1	\$1798.00

(U) Available while supplies last

HATA (FRAMON)

TKM-100 Leading the Industry in Tubular Key Cutting

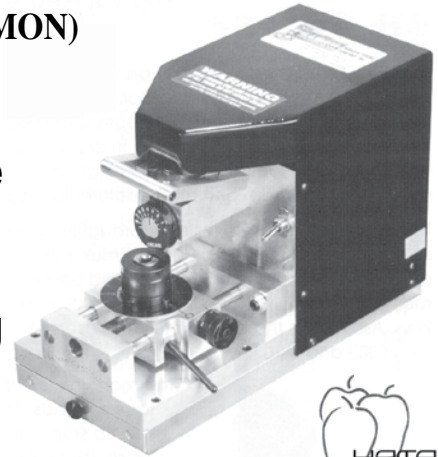

Known throughout the industry as the foremost machine in tubular key cutting. Everything you need to originate almost any tubular key in use today is included in the TKM-100. Tubular Key Machines

One Collet for All Your Needs

Features a collet that can accommodate all three size tubular keys. No fumbling with changing jaws or adapters. Simply tighten the chuck closer - the self adjusting collet easily accepts any size key (Diameter .365 - .406).

Make Any Type of Cut and Lots of Them!

Make regular cuts, ward cuts, and master cuts. Equipped with a carbide cutter, which means you can cut brass or steel and get long cutter life.

Why Code Cut When You Can Duplicate?

A tubular key wears very quickly. Due to the constant pressure on the face of the key, even original keys can be off .001" - .003". By using a duplicator to make a key, an inaccurate copy of a worn key is being made. When you use the TKM-100 to code cut a key, you'll be making an original key, accurate to .001". A precision dial indicator is included with the machine, which enables you to decode a tubular key for duplication in only a few seconds.

Dimensions: 10.5" W x 16" D x 8" H. Weight: 33 lbs.

Order #	Item #	Catalog Price
315-0030	TKM-100	\$3198.00

Some of the keys that can be cut on the TKM-100:

- Offset Left • Center • Offset Right • 8-pin (Ace)
- 8-pin (Fort) 8-pin (Segal) • 9-pin

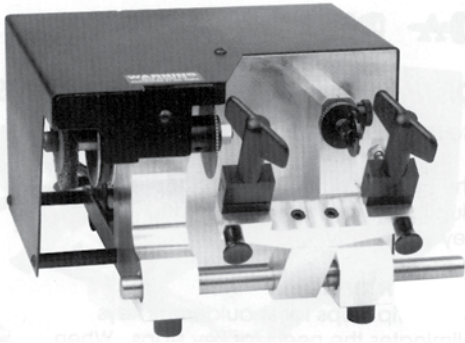

DBM-1 Flat Steel Key Duplicator
Makes Fast Work Out of Flat Steel Key Duplication

Designed to cut safety deposit box, locker, and padlock keys. This specialized flat key duplicator will duplicate blanks up to 3-1/2" long.

- Equipped with a .045" carbide slotter.
- Now features a wire deburring brush
- Rotating Guide for Different Cutter Widths.
- Widths available in .035", .055", .066", and .088". A .100" cut can be made by pairing the .045" and .055" cutters.
- Depth adjustments can be made in .001" increments.
- Sealed ball bearings are used in the spindle
- Built-in rod wipers keep the carriage rod clean as you cut keys.
- Guide locks in rearward position for easy tip alignment, no spring pressure.

Dimensions:
 10-1/2" W x 16" D x 6-1/4" H
 Weight: 33 lbs.



Order #	Item #	Catalog Price
315-0010	DBM-1	\$2258.00



Takes the original Sidewinder one step further!

Sidewinder 2
Duplicate & originate high security automotive keys



Originate high security keys as well as duplicate.

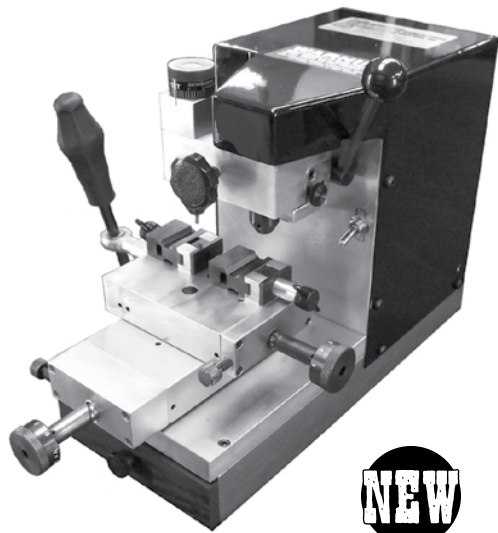

Duplication.

Includes everything needed to duplicate just about any high security key in use today. Two sets of vises, six cutters and three guides are included. With the Sidewinder 2 you'll be able to duplicate Mercedes, BMW, Lexus, Infiniti, Kia, Hyundai, Chevrolet, Pontiac, Volvo and Saab just to name a few.

Code Cutting.

Out of the box the Sidewinder 2 can originate Honda, Volkswagen & Audi keys. Depth and space "rods" are furnished with the machine. Changing the machine from a duplicator to a code machine takes about one minute. Depth & space rods will be available for almost all high security keys in use today.

Setup Keys.

Each pair of code rods is accompanied by a "setup key". This key helps the user to properly set the depth of cut.

Genericode ME Included. A coupon for a full version of Genericode ME is included with the Sidewinder 2.

Order #	Item #	Catalog Price
315-0005	Sidewinder 2	\$5998.00



**Totally Portable
High-Security
Automotive Key
Duplicator
mini
groove™**



- Accurately Duplicates High-Security Automotive Track Keys
- Powered by a Rechargeable 12 Volt DC Battery or From Your Vehicle Battery
- Extremely Affordable
- Completely Portable
- Made in the USA

Order #	Item #	Dealer Price
360-8000	8000MGDC	\$1998.00

**747XU *The Cadillac of
Tubular Key Machines.***

**DUPLICATES AND CUTS TO CODE ALL THREE
SIZE TUBULAR KEYS.**

Factory preset to cut standard size center sequence tubular keys by code.

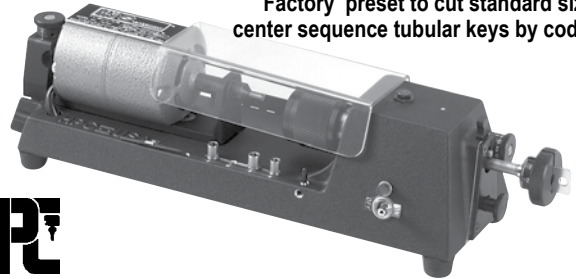

Compact, lightweight machine is designed to cut all three size (diameter) tubular "ace" type keys. The capability of the machine includes dead pin cuts, right and left cut keys, eight depth cuts, and double cuts in any position. This machine will also duplicate any key - important for non-standard depth increments. The positive decoding mechanism is the first of its kind. Carbide cutter standard. 110 volt AC.

750-1747	SCO-747XU	\$2500.00
-----------------	------------------	------------------

Tubular Key Machines

**Pocket
Cut-Up™
Portable
Tubular
Key Machine**



TKM-90. Compact, light, & portable. (closed, less than 4" long & only 1-3/4" in diameter). Offset left sequence & right sequence (including dead pin cuts) cut with one simple adjustment. Cuts Greenwald style tubular keys. Blank held firmly in place by swing-away key holding fixture which also locks micrometer depth adjustment knob at preselected depths. Turning cutter knob operates specially engineered carbide cutter, & brass or steel blanks cut manually with ease. Included adaptor allows key cutting operation by use of a cordless screwdriver. Packed in a compact carrying case with HPC's Tubular Key/Pick decoder.

360-9090	HPC-TKM-90	\$666.00
-----------------	-------------------	-----------------

Mini Speedex® Lightweight Key Duplicator

The most accurate small key machine on the market. Has 4-way jaws which allow a wide variety of key cuts. Cut regular or large-bow keys. Comes with HPC Softie rotary brush. Durable construction and bronze bearings combine for a long lasting product. Its portable size and weight make the Mini Speedex convenient to use in your lockshop or van. With CW 23RM cutter.

- 120 V AC 1/10H.P., 1.5 Amps. Wt. 16 lbs.
- Machine Size: 11"W x 8"D x 8"H. •

Order #	Item #	Catalog Price
360-9120	HPC-9120RM	\$740.00
360-9121	9120-B Belt for 9120RM	14.14
360-0098	CW-23RM Std. Cutter for 9120RM	95.00

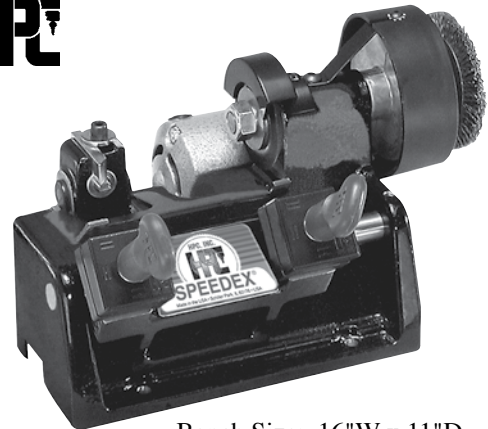

Bench Size: 16"W x 11"D

Premier Speedex® Manual Key Duplicator

Perfect for the largest of keys, hotel/motel room keys. Equipped with 4-way jaws. Reversible copy dog allows you to cut flat steel keys with optional slotting cutter kit (CW-16KIT). Mounted on a sturdy base and equipped with a heavy-duty motor. Steel construction and bronze bearings. 120V AC 1/6 HP, 3.5 Amps.

- Weight: 30 lbs. • With CW-23MC Cutter.
- Size: 12"W x 14" D x 8" H

Order #	Item #	Catalog Price
360-9160	HPC-9160MC	\$980.00

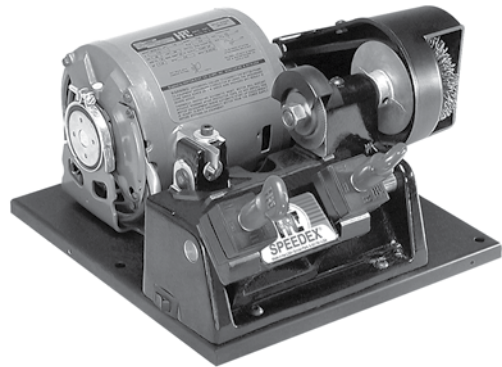

Cut Flat Steel and Safe Deposit box keys with optional kit:

360-9101	CW16KIT	\$109.50
----------	---------	-----------------

Key Cutters

Power Speedex® Semi-Automatic Key Duplicator with Cover

A Semi-automatic duplicator that is operated by a spring-loaded carriage with a safety release. This design allows the carriage to move smoothly with the use of one hand when cutting keys. Also has a built-in light and molded plastic cover that encloses the motor. 4-way jaws enable it to hold a large variety of different key blanks, including double-sided and large bow keys. The reversible copy dog allows you to cut flat steel keys with the optional CW-16 slotting cutter kit. Mounted on a sturdy base and comes equipped with the HPC Softie de-burring brush.

- CW-23MC Cutter supplied.
- Machine size: 13"W x 16" D x 10" H.

Order #	Item #	Catalog Price
360-9180	HPC 9180MC	\$1270.00

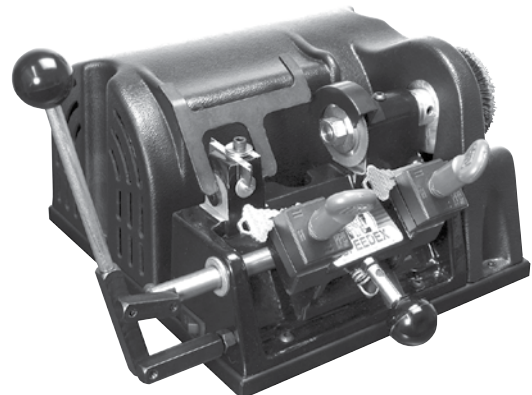

• Bench Size: 18"W x 19"D

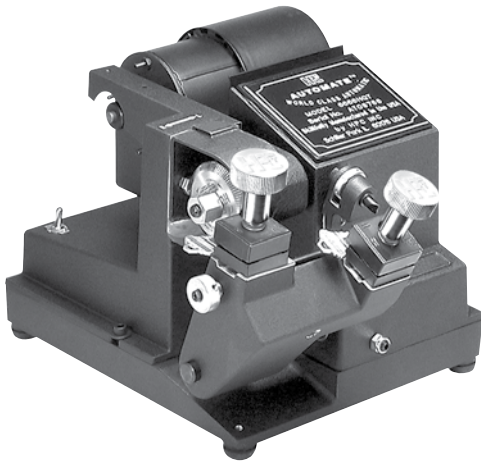

The Automate® Fully Automatic Key Duplicator

Completely automatic action allows for total hands-free operation. The entire cutting cycle takes on 20 seconds. 4-way jaws allow it to cut a wide variety of keys. Spring loaded carriage assures consistent duplication. New expanded range of travel allows for the cutting of longer automotive keys. Cuts accurately and effortlessly. 120VAC, 1/6 HP, 3.7 amps. Weight: 32 lbs.

Machine Size: 12"W x 16" D x 11"H

Bench Size: 19"W x 16"D.

Cutter supplied: CW-42HQT

Order #	Item #	Cutter	Price
360-0535	6666HQT	Tool Steel	\$2390.00



By Popular Demand
The Classic is Back:

HPC's Trace-A-Key®

An extremely versatile key duplicating machine. Simply place the original key in the right hand jaw, place the new blank in the left hand jaw, and push down on the carriage knob, while simultaneously moving the lever to the right. This action glides the key to be cut across the tracer cutting the new key effortlessly. The spring loaded carriage assures consistent cutting duplication. Its double-sided jaws and expansive carriage range allow for the cutting of longer automotive keys. Standard 120 volt.

Order #	Item #	Catalog Price
360-0530	3344HQT	\$1998.00

The Blitz™

The Blitz™ is HPC's second generation of the 1200CM Code Machine, working exactly the same as the 1200CM, but with additional features. The depth & spacing shafts have fewer threads per inch, meaning fewer revolutions are needed to achieve full range of travel. It also features a shoulder gauge with safety cut-off switch, and is equipped with HPC's Softie™ deburring brush with a safety shield.

Simple to use and extremely versatile. It cuts by actual manufacturers' depths and spaces. There is no need to convert to micrometer readings. With its rotating cutter head, the Blitz™ can make high security angle cuts. With optional accessories the Blitz™ can cut flat steel keys, Medeco® Biaxial®, Schlage Primus®, as well as many other specialty keys.

Cuts accurate keys by code quickly and easily. Easily change from one manufacturer's specifications to another. Radically different changes can be set up in 10 to 30 seconds without wasting key blanks.

Uses code cards, which are inserted in the code machine. These cards have depth and space indicators, plus all the pertinent information such as cutter, jaw, code series, blanks, and any special information you may need. Depth and space adjustments are never required

The Blitz™

TECHNICAL INFORMATION

Motor..... 120VAC (1/6 hp, 3.5 amps) • Weight..... 34 lbs/15.4kg
 Machine Size12"W x 14"D x 9"H • Bench Size.....20"W x 14"D

Cutters Supplied: 1) Tool Steel, 100° large cylinder.....#CW-14MC
 2) Tool Steel, 90° small cylinder.....#CW-1011

Accessories Included:

- 1) Softie™ Brush
- 2) Interactive Depth & Spacing Guide.....#HDSB-CD
- 3) Code Cards 112 code cards/8 micrometer cards....#DECK-120
- 4) Binder (for 120 cards) with Manual.....#CARD-B
- 5) Horseshoe Tip Stop.....#CM-1054R
- 4) Red Tip Stop.....#CM1054MA
- 6) Brass Plated Key Shim.....#KBPS-1
- 7) Cutter/Adjustment Wrench....#WRENCH-1
- 8) Space Adjustment Wrench....#WRENCH-2
- 9) Cutter Nut Wrench.....#WRENCH-3

Order #	Item #	Price
360-0540	1200CMB	\$4712.00
360-0542	1200CMB AC/DC	5328.00

Jaws for 1200CMB

360-E054	CM1056MA	\$58.14
----------	----------	----------------

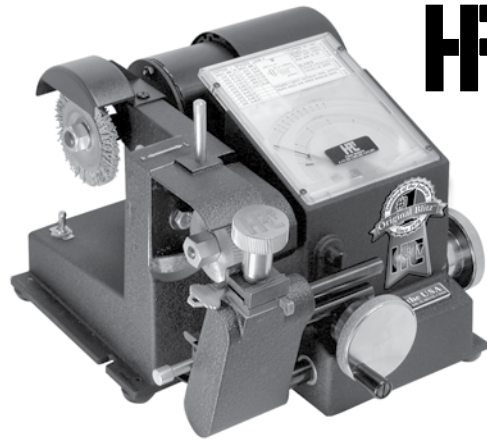

when changing from one manufacturer to another. The Blitz™ Code Machine is a must for those who create master key systems or do code work.

1200CMB Series Key Machines now include the new 1200CMB Shoulder Gauge Switch and HPC's Interactive Depth & Spacing Guide (HDSB-CD).

GET the CodeSource™ Code Retrieval Software (CS-CD) from HPC when you register your machine (subject to change, check HPC 's website for up-to-date information).

For those people who currently own a 1200CM style key machine and want to upgrade to a Blitz™, HPC offers a conversion program. Give us a call for details.

1200CMB: CW-20FM Corbin, Russwin, Sargent, radius tooth cutter. (Use no substitute)

Order #	Item #	PRICE
360-0095	CW 20FM	\$193.00

The 1200CMB Cuts Standard

MEDECO Keys! Key Cutters

Cutter Head Swivels with optional cutter & jaw:

Order #	Item #	Description	PRICE
360-0245	MJ-1	Medeco Jaw	\$136.04
360-0114	CW1012	Medeco Cutter	190.50

1200CMB Series Code Cards

Complete Deck of 120 Cards

Order #	Item #	PRICE
360-2120	HPC Deck-120	\$950.00

HPC Blitz Family

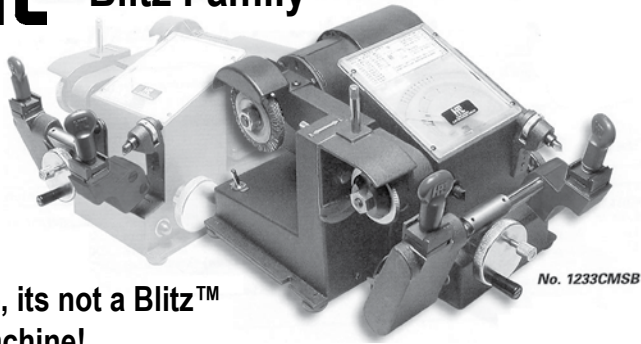

No, its not a Blitz™ Machine!

It's the Switch Blitz™
2 Machines in 1 - Cut by Code and Duplicate!

If you can't decide whether to buy a code machine or a duplicator . . .
If you only have space for one key machine . . .
If you love the Blitz, but really need a duplicator . . .
The Switch Blitz is the machine for you.

The "Standard of the Industry" has yielded another winner. The new Switch Blitz combines the best of both worlds. Its a Blitz code machine combined with a semi-automatic duplicator. Now you can have two world-class key machines in the bench space of one. Easily switch from code cutting to duplication and back again. Uses the same code cards as your Blitz and 1200CM. (Includes 120 Code Cards).

Order #	Item #	Catalog Price
360-0550	1233CMSB	\$5760.00

Extreme Blitz™ HPC

No. 1200CMBX

- 3 Cutters (CW-1011, CW-14MC, CS-47MC)
- 175 Code Cards
- MasterKing Combo Pack (Includes How to Master Key)
- Tubular Key Adaptor • Calibration kit

For the locksmith who wants it all. The Extreme Blitz™ offers a total package. Perfect for a new locksmith, a new van, or a new shop.

Order #	Item #	Catalog Price
360-0539	1200CMBX	\$5500.00

Blitz Tubular Key Adapter Kit

HPC's new Blitz Tubular key Adapter Kit is the most economical answer to code cutting for your tubular keys. Allows you to convert your Blitz machine into a tubular key cutter. It is factory preset to cut standard 7-pin tubular keys by code, eliminating any guesswork. Fits in the standard "A" jaw making conversion quick and easy. Kit comes with an Adapter, Cabide Slotter Cutter, a Tubular Key Code Card, and an Allen wrench. Plus, with the included Tubular key Decoder, you can quickly decode existing tubular keys and make new factory originals by code. Fast, easy, accurate, and economical; a valuable addition to your Blitz Code machine.

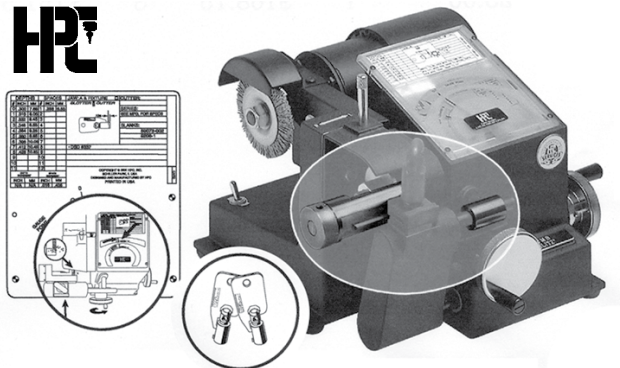

Order #	Item #	Price
360-0004	TKA-CMB	\$515.00



Parts

Automotive Super Jaw Kit No. ASJ-1200



HPC's Automotive Super Jaw Kit fits your Blitz™ and helps you cut double-sided automotive keys without shims and wires that are easily lost or misplaced. Your time is precious and you'll save carloads of it with this essential automotive key cutting kit. This kit comes with everything you need including 20 new code cards to keep you up-to-date. Collect your cash and get your customers on the road faster with this vital vehicle key cutting kit from HPC!

Order #	Item #	Catalog Price
360-0310	ASJ-1200	\$308.98

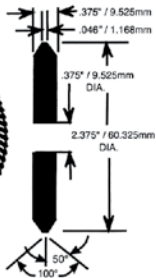

1200 Series Key Cutters HPC CW-14MC

100° angle, standard large cylinder cutter

Order #	Item #	Catalog Price
360-0090	14MC	\$190.90

Schlage Primus Jaw

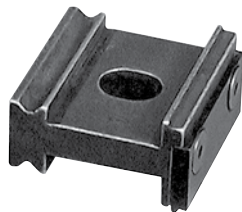

Use with Blitz, 1200CM & Codemax

Increased demand for Schlage's high security Primus Key has led to the development of HPC's new Schlage Primus Jaw. It grips the specialized key blank tightly, allowing for an accurately cut key every time. The jaw also works with Schlage Quad Keyways. (This jaw isn't necessary for the Punch Machine, the standard jaw holds Primus securely.)

Order #	Item #	Price
360-1201	HPC SPJ-1	\$99.92



non-stock



Also NEW!

Shoulder Gauge Safety Switch!

This new addition to all CodeMax models ensures that your shoulder gauge is out of the way before you start cutting keys.

CodeMax™ AA

The Original Computerized Code Machine now available with the Automatic Angler!

NEW Automatic Angler

Just type in the code and watch the new motordriven swivel head automatically create high security angle cuts!

CodeMax Features:

- Cuts keys with up to 14 depths and 14 spaces.
- Contains over 800 different depth and spacing charts.
- Download and quickly cut a master key system from HPC's MasterKing software.
- Backed by the HPC Technical Support Department.
- Adjustable feed rate!
- Contour (laser) cutting for automatic keys.
- Built-in micrometer functions in inches or millimeters.

Order #	Item #	Price
Special Order	1200MAXAA	\$ CALL

Drop Ship Item.

HPC CodeMax™

Fully Automatic Computerized Key Machine

CodeMax, the original computerized code machine, comes complete with CodeSource code retrieval program. Based on the industry standard 1200CMB machine, CodeMax was the first machine to put the power of a computer into key cutting. HPC's CodeSource has a database of well over 2 million codes that can be accessed quickly and easily from your Windows based PC and downloaded to your CodeMax..

As a stand alone machine, CodeMax has an internal computer chip that contains over 600 different depth and spacing charts. It can cut keys with up to 14 spaces and up to 14 depths. This allows it to cut virtually all standard vehicle, commercial, residential, furniture keys, as well as many high security and specialty keys.

The easy-to-use reference manual makes it simple to look up the proper depth and spacing charts. After entering the appropriate information, CodeMax will confirm the manufacturer and inform you of the proper gauging point. It then allows you to enter the depths of your choice. Once this has been done, CodeMax will create an original key in seconds.

Has a built-in micrometer function allowing you to create keys at a depth and spacing measurement. Plus it allows you to adjust the "feed rate" as well as offers the option of contour (laser) cutting for automotive keys. CodeMax with CodeSource is the ultimate computerized key originating package.

Comes with five cutter wheels (CW-1011, CW-14MC, CW-90MC, CW-20FM and CW-47MC). With the optional Medeco® cutter (CW1012) and jaw (MJ-1), Codemax™ is ready to cut Medeco® brand keys, including Biaxial™.

Accessories Included:

- Horseshoe Tip Stop • Depth & Spacing Book
- Cutter/Adjustment Wrench • Manual • Cutter Wrench

Medeco® is a registered trademark of Medeco Security Locks.

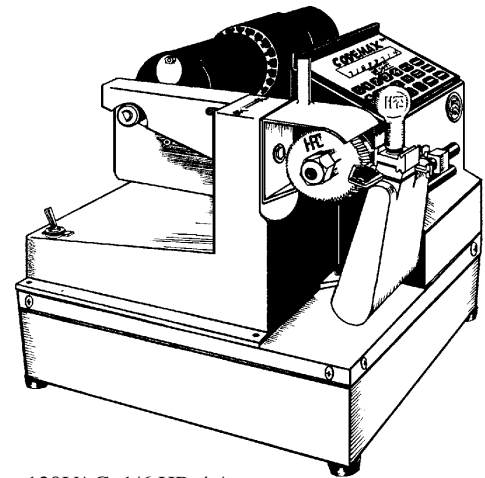

120VAC, 1/6 HP, 4 Amps.

- 14" High x 12" Wide x 14" Deep
- Bench Size: 12"W x 14"D • Wt: 42 lbs.

Codemax Key Machine:

Order #: 360-1120 | \$9190.00

Cable for IBM versions of HPC Software and Codemax: \$182.72

360-2210 | (U) CABLE-25S

Minimum System Requirements:

IBM Compatible, 386 Microprocessor, 4 MB RAM, Windows 3.1, VGA Monitor



1200PCH

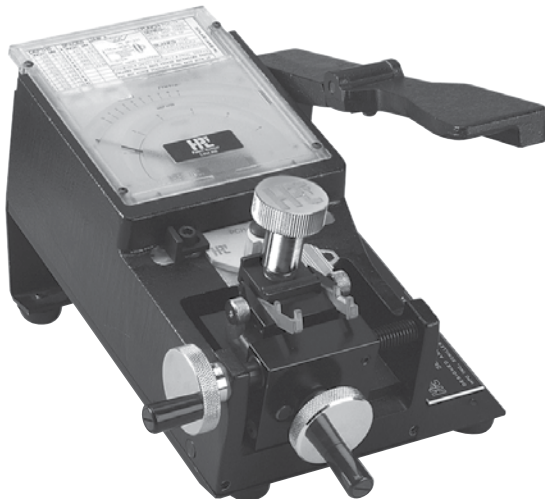

Punch Machines

Works on same principle as the 1200CMB, making it the most versatile punch machine on the market. Extremely accurate and completely portable. Depth and space adjustments are not required in changing from one manufacturer to another. Complete with 83 code cards.

Punches Supplied:

PCH-1011, PCH-14, & PCH-1014

Machine Size: 9" wide x 12" deep x 6 1/4" High

Bench Size: 9" wide x 12" deep; **Weight:** 13 lbs.

Other Accessories Included:

- 79 code cards and 4 micrometer cards.
- HPC Depth & Spacing Book. • Wrenches
- Allen Wrench, • Manual

Order #	Item #	PRICE
360-0523	1200PCH	\$3198.00

HPC

HPC 1200CMB Calibration Kit

Easy to use kit is for all Blitz and 1200CM Code Machines. Designed to quickly and accurately diagnose machine calibration. If it is out of calibration, the kit can be used to calibrate your machine with just a few simple steps or determine whether factory service is needed. Helps to eliminate unnecessary downtime.

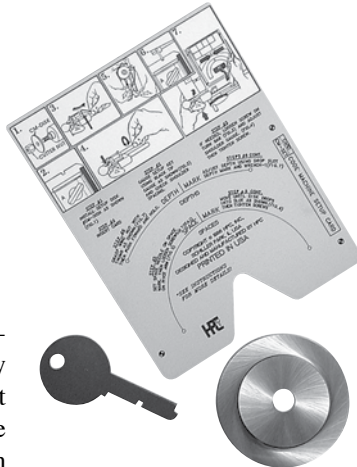

Order #	Item #	Catalog Price
360-1951	HPC CMB-CK	\$128.44

HPC

HPC

CARD-BP

Extra card storage panel holds 40 more code cards.



Order #	Catalog Price
360-0044	\$36.42

Tiger SHARK™

- The HPC Tiger SHARK™ is the easiest code machine to use and will quickly become your favorite.
- The HPC Tiger SHARK™ has an extensive database of automotive, padlock and furniture codes; a complete database of lock manufacturer's commercial and residential direct digit codes; and a vast key blank cross reference making the Tiger SHARK™ ideal for independent and institutional locksmiths.
- The HPC Tiger SHARK™ has an intuitive touch-screen with easy to follow prompts, so you'll be cutting all types of keys right out of the box.
- The HPC Tiger SHARK™ has a wide-open carriage area with a polished steel back plate providing a mirror image of the carriage for added visibility. The Quick Nut makes changing cutters easy. 4-way jaws topped with the Easy Grip Wing Nut securely hold virtually all keys including double-sided automotive keys.
- The HPC Tiger SHARK's versatile design and innovative optional adapters allow you to cut specialty keys including tubular and Tibbe.
- If you are looking for one machine to handle all of your code cutting, from single keys to complex master key systems, the HPC Tiger SHARK™ is your answer.

Order #	Item #	Catalog Price*
360-0123	123TSHARK	\$10,600.00

Tiger SHARK™

NEW





UNIVERSAL II

The Ultimate “Card Type” Code Machine for Originating Commercial, Residential, and Automotive Keys

Best Features, Best Value, Best Choice

The Universal II allows the operator to cut different keys in seconds:

- Simply insert the code card for the intended lock application into the machine.
- Create the desired cuts by rotating the machine’s depth and spacing cranks.
- Change to another manufacturer or application by removing the original code card and inserting another.

Code cards are identified by both lock manufacturer and Ilco card number. Easy-to-use, informative cards include space and depth markings and tables, the correct cutter to use, vise jaw position, key gaging method, and correct key blank.

Features

- Utilizes code cards, allowing the operator to change the machine setup quickly and add new applications at minimal cost.
- Easy view code card design enhances accuracy and speed.
- Superior dial depth adjustment system provides quicker, more precise calibration.
- “Flapper style” key blank alignment gage ensures accurate, level key placement.
- Titanium nitride coating provides extra long cutter life.
- Quick rate depth and spacing drive shafts speed up the key cutting process.
- Up-to-date card selection covers current key applications.
- Tilting cutter head for making angled cuts on Medeco® keys and similar types.
- Capacitor start motor enables use with 12 volt DC power inverters.
- Durable powder coat finish.

Technical Specifications

- Voltage: 110VAC/3.5 Amps Standard
- Motor: 1/4hp (capacitor start type)
- Weight: 37.5 lbs (17.04 kg.)
- Dimensions: 12” Wide x 14” Deep x 10” High

Included Accessories

- Code Cards: 112 Commercial/Residential/Automotive code cards/8 micrometer cards.
- Binder with code card holders



- Standard and U-shaped tipstops
- Steel stabilizer shim
- T14MC and TCW-1011 cutters
- Tools to change cutters and adjust machine.

Order #	Item #	Catalog Price
400-3000	UNIVERSAL II	\$4802.00

ILCO Key Cutters for the Universal II Code Machine

- TCW-90MC. 90° cutter (IC core) Recommended for most IC core applications.
- TCW-47MC. 87° cutter (automotive) 87° angle required for some automotive applications.
- TCW-20FM. 76° cutter (Sargent keys) 76° angle with flat mill tooth profile for Sargent.

Order #	Item #	Catalog Price
400-3005	TCW-90MC	\$190.90
400-3010	TCW-47MC	190.90
400-3015	TCW-20FM	190.90



Tri-Code H.S.

Electronic Key Machine Specifically Designed to be Used by Automotive Dealers and Locksmiths, to cut “laser style” high security by code number or duplication.

The Triax A/T electronic key machine, for high security keys, has been discontinued and is being replaced by the Tri-Code H.S. Like the Triax A/T, the Tri-Code is an electronic model designed for cutting high security “laser type” keys for automotive applications by duplication, biting number, or indirect code.

The Tri-Code H.S. retains popular features from its predecessor such as straightforward screen menus, soft touch keypad, easy-to-view LCD screen, large safety shield, and simple operation. It is covered by a three year manufacturer’s warranty and one year free update coverage.

- Three position vise clamp: Broad range of vehicles covered “right out of the box”.
- One cutter: The machine utilizes a single cutter for all covered lock applications.
- Built in tip stops. No accessory tip stop components to lose.

The Tri-Code H.S. cuts the popular laser type, high security automotive keys by code, biting number or duplication. Simple to operate, this machine will eliminate the guesswork and effort associated with cutting laser type automotive keys. If key wear is detected when duplicating, the machine converts back to the original factory specifications with tolerances of +/- .001”.



No set-up or calibration required. It’s fully equipped and ready to cut keys once you remove it from the box.

Order #	Item #	Catalog Price
400-3200	Tri-Code HS	\$16,156.00

Available by Special Order.

Duplicates Cylinder and Automotive Keys

An automatic/manual function machine designed to be operated as either an automatic or manual type duplicator. Accepts longer length keys and those with oversize heads. Equipped with Super Jaw 2, four-way vises, and 040 grips virtually any cylinder key without the need for adapters. Offset carriage allows for gauging keys from the tips where necessary. Accurate, simple to operate, and versatile.

- Dial type depth adjustment system.
- Cover constructed of high strength, impact resistant material.
- Duplicates virtually all cylinder keys on the market.
- Features “Soft Touch” deburring brush.
- Cutting cycle is 18 seconds

Motor: 110V 1/4 HP **Cutter:** CU20 milling cutter
Dimensions: 15.5”W x 16” D x 8.5” H. **Weight:** 36 lbs.

PERFORMANCE Series

040 Manual/Automatic



040

Order #	Item #	Model	Price
400-3240	040-110V	Automatic	\$1710.00

Duplicates Cylinder and Automotive Keys

Fast and Accurate! Once keys are loaded, release the carriage mechanism and, with one easy flip of the operating lever, an accurate duplicate is made. Especially useful when a customer wants 5, 10, 25 or more copies of the same key. Equipped with versatile Super Jaw 2 four-way vise jaws, the 044 provides superior key gripping characteristics and the ability to duplicate almost any standard cylinder key.

- Wide spacing between vise jaws, accommodates new, longer key types.
- Dial type depth adjustment system
- Ideal for mobile use: efficient 1/4 HP motor operates with most inverters & generators that supply 500 watts or higher output.
- Spring loaded carriage for constant cutting pressure
- “Soft-Touch” deburring brush.
- Circuit breaker protected and • Chip tray provided.

Motor: 110V 1/4 HP • **Cutter:** CU20 milling cutter, flat left side
Dimensions: 14.5”W x 16” D x 10” H. **Weight:** 35 lbs.

PERFORMANCE Series

044 Lever Operated Duplicator



044

Order #	Item #	Model	Price
400-3244	044-110V	Semi-Auto.	\$1776.00

All meet OSHA and CSA/NRTL/C requirements

Duplicates Cylinder and Automotive Keys

A real money-maker. Economical, accurate & simple to operate.

- Wide spacing between vise jaws, accommodates new, longer key types.
- Dial type depth adjustment system
- Ideal for mobile use: efficient 1/4 HP motor operates with most inverters & generators that supply 500 watts or higher output.
- Four-way reversible vise jaws securely clamp keys without adapters, including double-sided types.
- “Soft-Touch” deburring brush.
- Circuit breaker protected and • Chip tray provided.

Motor: 110V 1/4 HP **Cutter:** P-X23MC
Dimensions: 14.5”W x 17.5” D x 8.75” H. **Weight:** 33 lbs.

PERFORMANCE Series

045 Manual

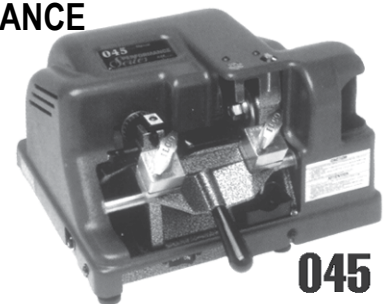

045

Order #	Item #	Model	Price
400-3245	045-110V	Manual	\$1376.00

040 HD Automatic/Manual



The 040 HD is an automatic/manual function machine designed to be operated as either an automatic or manual type duplicator. The 040 accepts longer length keys and those with oversize heads. Equipped with SuperJaw 3 four-position vise jaws, the 040 HD grips virtually any cylinder key without the need for adapters. The offset carriage allows for gauging keys from the tips where necessary. Accurate, simple to operate, versatile ...the 040 HD may be just the machine you're looking for!



- Super Jaw 3, "secure grip", four-position vise jaws; securely clamps most residential, padlock, or automotive keys without the need for adapters, including double-sided types.
- Permanently lubricated cutter spindle shaft ball bearings rather than bushings; bearings are usually found on more expensive models.
- Hardened carriage shaft and cutter spindle provide extended service life.
- Fast spindle speed provides smoother cuts
- Titanium coated P-CU20 milling cutter; made from quality, hardened tool steel.
- Dial type depth adjustment system greatly simplifies calibration and improves accuracy.
- Built in circuit breaker protection.
- Dual function - Operate in Automatic mode for convenience or Manual mode for special situations.
- Accommodates large bow and long blade keys.
- Features a "Soft Touch" deburring brush.

The 040 HD is designed to duplicate typical automotive and commercial keys, including those with large bows or long blades. Designed primarily as an automatic style machine, the 040 HD can also be operated manually. Super Jaw 3 vises feature four clamping positions to securely grip virtually any key. A versatile machine that is easy to operate.

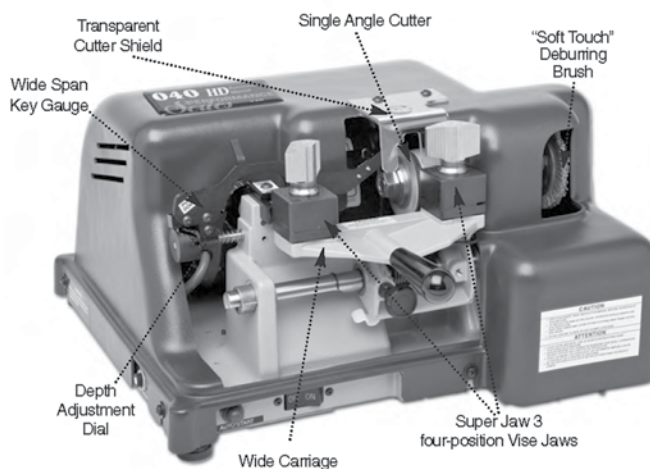

Motor: 110V-AC standard

Vise Jaws: Super Jaw 3, four position

Cutter: P-CU20 milling cutter, flat left side

Brush: 814-00-51

Dimensions: 15 1/2" W x 16" D x 8 1/2" H
(39.4cm x 40.6cm x 21.6cm)

Weight: 28.9 lbs. (13.11 kg)

Meets OSHA and CSA/NRTL/C requirements

Duplicates Cylinder and Automotive Keys

Order #	Item #	Catalog Price
400-7040	040 HD-110VAC	\$1998.00

044 HD



Lever Operated Duplicator

The 044 HD Performance Series Key Duplicator is particularly useful when multiple duplicates of a key are needed. Features of the model include the Super Jaw 3, four-position vise jaws to provide superior key "grip" on virtually any standard cylinder key. The semi-automatic design allows the operator to duplicate with speed and accuracy. Function, combined with attractive styling, makes the 044 HD an excellent choice for standard key duplication.



- Super Jaw 3, "secure grip", four-position vise jaws; securely clamps most residential, padlock, or automotive keys without the need for adapters, including double-sided types.
- Permanently lubricated cutter spindle shaft ball bearings rather than bushings; bearings are usually found on more expensive models.
- Hardened carriage shaft and cutter spindle provide extended service life.
- Fast spindle speed provides smoother cuts
- Titanium coated P-CU20 milling cutter; made from quality, hardened tool steel.
- Wide spacing between vise jaws, accommodates longer key types.
- Dial type depth adjustment system greatly simplifies calibration and improves accuracy.
- Ideal for mobile use, efficient 1/4 hp motor will operate with most inverters and generators that supply 500 watts(continuous) or higher output (115VAC)
- Special device guards against cutter contact with vise jaws.
- Circuit breaker protected.

The 044 HD is fast, accurate and designed for years of use! Once keys are loaded, simply release the carriage mechanism and with one easy flip of the operating lever, an accurate duplicate is made.
... It's that easy!

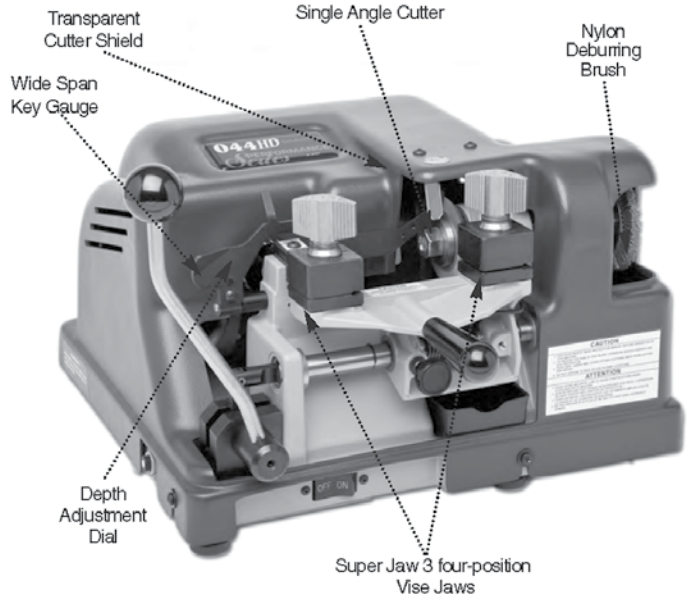

Motor: 110V-AC standard
Vise Jaws: Super Jaw 3, four position
Cutter: P-CU20 milling cutter, flat left side
Brush: 814-00-51
Dimensions: 14 1/2" W x 16" D x 10" H
 (32cm x 35cm x 25cm)
Weight: 28.3 lbs. (12.84 kg)

Meets OSHA and CSA/NRTL/C requirements

Duplicates Cylinder and Automotive Keys

Order #	Item #	Catalog Price
400-7044	044 HD-110VAC	\$1846.00

045 HD Manual Duplicator



A real money-maker, the 045 is the perfect basic key duplicator, ideal for virtually any key cutting outlet. Economical, accurate, and simple to operate, the 045 HD is loaded with useful features any user will readily appreciate. Its performance tested design makes it an excellent choice for store, shop or mobile use. Performance tested to assure years of dependable service.

- Super Jaw 3, “secure grip”, four-position vise jaws; securely clamps most residential, padlock, or automotive keys without the need for adapters, including double-sided types.
- Permanently lubricated cutter spindle shaft ball bearings rather than bushings; bearings are usually found on more expensive models.
- Hardened carriage shaft and cutter spindle provide extended service life.
- Wide spacing between vise jaws; accommodates longer key types.
- Dial type depth adjustment system greatly simplifies calibration and improves accuracy.
- Ideal for shop or mobile use; efficient 1/4 HP motor will operate with most inverters and generators that supply 500 watts (continuous) or higher output (115 Volt AC).
- Special depth limit device guards against cutter contact with vise jaws.
- Features a “soft-touch” deburring brush.
- Cutter is made of high speed tool steel, coated with titanium nitride for longer cutting life.
- Built in circuit breaker protection.



Accurate, economical, and easy to use, the 045 HD is the perfect basic duplicator for virtually any store or shop. Wide vise jaw spacing, Super Jaw 3, “secure grip” visejaws, dial type depth adjustment, and simple operation are just a few reasons that the 045 is the manual style duplicator of choice for so many!

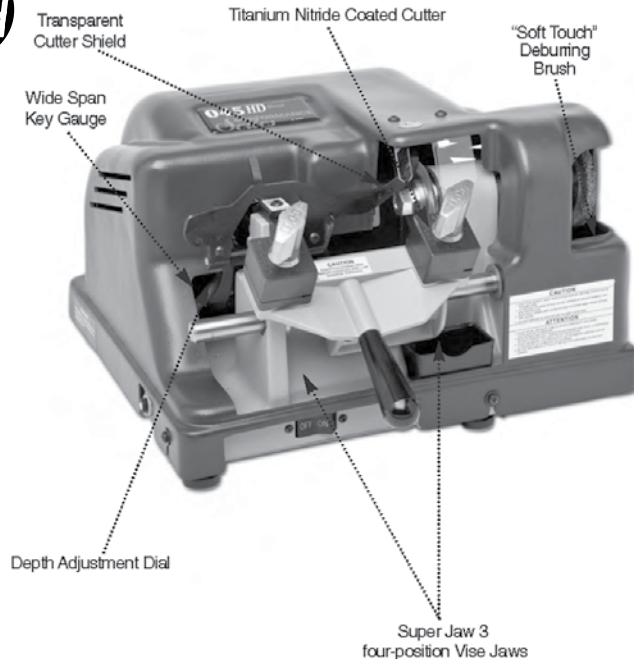

Motor: 110V-AC standard
Vise Jaws: Super Jaw 3, four position
Cutter: P-X23MC: titanium coated
Brush: 814-00-51
Dimensions: 14-1/2" W x 17-1/2" D x 8-3/4" H
 (36.8cm x 44.5cm x 25cm)
Weight: 26.1 lbs. (11.85 kg)

Meets OSHA and CSA/NRTL/C requirements

Duplicates Cylinder and Automotive Keys

Order #	Item #	Catalog Price
400-7045	045 HD-110VAC	\$1484.00

046 HD Flat Steel and Safe Deposit Key Duplicator



Accurate, economical and easy to use. Wide vise jaw spacing, permanently lubricated cutter spindle bearings, Super Jaw 3, "secure grip" vise jaws, hardened carriage shaft, and much more. The perfect basic duplicator for cutting flat style keys.

The perfect basic duplicator for flat style keys! Accurate, economical, and easy to operate, the 046 HD is the ideal solution for duplicating safe deposit and similar flat type keys. Loaded with useful features that any user will appreciate, it is an excellent choice for either shop or mobile use. Performance tested design assures years of dependable service.



- Super Jaw 3, "secure grip", four-position vise jaws securely clamp flat keys without the need for adapters.
- Permanently lubricated cutter spindle shaft ball bearings rather than bushings; bearings are usually found on more expensive models.
- Hardened carriage shaft and cutter spindle provide extended service life.
- Wide spacing between vise jaws; accommodates longer key types.
- Dial type depth adjustment system greatly simplifies calibration and improves accuracy.
- Ideal for shop or mobile use; efficient 1/4 hp motor will operate with most invertors and generators that supply 500 watts (continuous) or higher output (115 VoltAC).
- Special depth limit device guards against cutter contact with vise jaws.
- Features a "soft-touch" deburring brush.
- Cutter is made of high speed tool steel, coated with titanium nitride for longer cutting life.
- Built in circuit breaker protection.

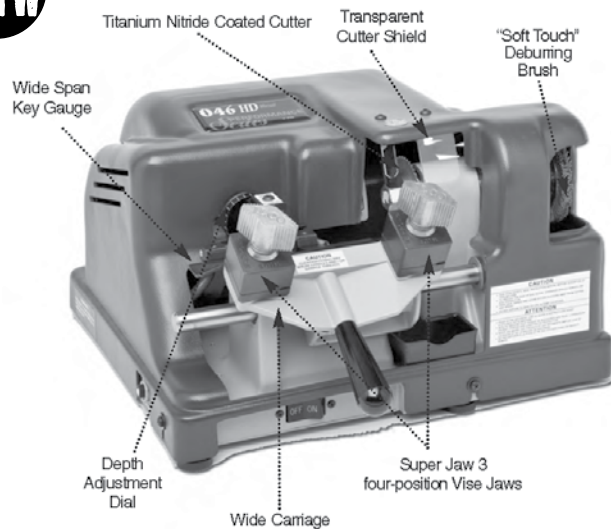

Motor: 110V-AC standard; 1/4 hp, 1725 rpm
Vise Jaws: Super Jaw 3, four position
Cutter: P-45SMS: titanium coated
Brush: 814-00-51
Dimensions: 14-1/2"W x 17-1/2" D x 8-3/4" H
 (36.8cm x 44.5cm x 22.2cm)
Weight: 26.1 lbs. (11.84 kg)

Meets OSHA and CSA/NRTL/C requirements

Duplicates Flat Keys

Order #	Item #	* Catalog Price
400-7046	046 HD-110VAC	\$1568.00

PERFORMANCE
Series

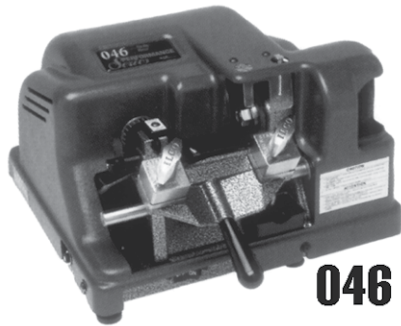

046
Manual

046

**Duplicates Flat Steel
and Safe Deposit Keys**

The perfect basic duplicator for flat style keys!
Accurate, economical, and easy to operate.

- Wide spacing between vise jaws, accommodates new, longer key types.
- Dial type depth adjustment system
- Ideal for mobile use: efficient 1/4 HP motor operates with most inverters & generators that supply 500 watts or higher output.
- Four-way reversible vise jaws securely clamp keys without adapters, including double-sided types.
- “Soft-Touch” deburring brush.
- Circuit breaker protected and • Chip tray provided.

Motor: 110V 1/4 HP

Cutter: P-45SMS

Dimensions: 14.5”W x 17.5” D x 8.75” H.

Weight: 33 lbs.

Order #	Item #	Model	Price
400-3246	046-110V	Manual	\$1458.00

Meets OSHA and CSA/NRTL/C requirements

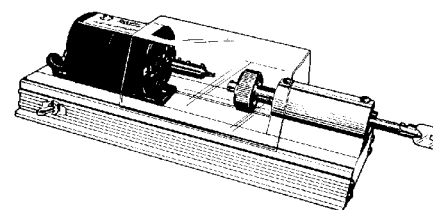

Tubular
009-50-44

Perfect addition to your shop or van. Easy to set up & operate. Duplicates accurately in seconds. Unique, positive indexing feature assures fast accurate location of each cut.

Shipping wt: 8 lbs.

Order #	Item #	Voltage	Price
400-2005	009-50-44	110VAC	\$1104.00



**BRAVO III USA
Semi-Automatic Machine**

With 4 way jaws. Rigid manufacturing tolerances make this machine one of the most accurate on the market. Features a micrometer adjustment for the tracer point, a twin rod carriage operation with sealed bushings, nylon deburring brush and a removable chip tray. 15" x 15" x 11" high. 110 volts, .25 HP, 900 cutter rpm, 40 lbs.

Now with **CU50A** cutter, better suited for the broad range of cylinder keys now common in the North American market including Titan, older GM and others that have 90° "first cut" biting characteristics.

820-0030	BRAVO III	\$4316.00
----------	-----------	------------------

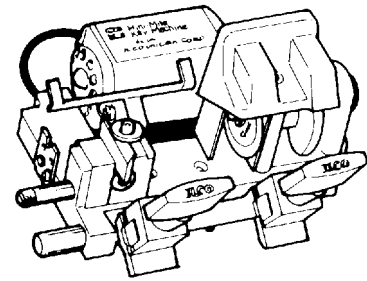

**Mini-Mite
008-50-44.**

Power packed portable with the "Shop" features you want.

- Reversible vises to cut single and double sided keys.
- High speed motor.
- Equipped with 23RF cutter.
- Four sided key rake for deburring keys.
- Hood covers moving parts and meets OSHA requirements.
- Carriage accepts all size key blanks including Hotel keys.
- Gauge fork aligns key blanks accurately. Shipping wt: 10 lbs.

Order #	Item #	Voltage	Price
400-2002	008-50-44	110VAC	\$832.00
400-2003	(U) 008-40-44	12VDC	912.00

IND-27X. Slotter

Parts, Key Cutters

Mini-Mite, when equipped with the #27 Slotter, cuts flat steel keys. Accessory package includes slotter, washer, & instruction sheet. (Stylus supplied with your machine is reversible to accommodate slotter.)

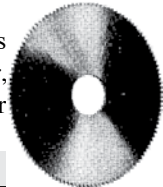

400-2028	27X Slotter	\$75.10
----------	-------------	----------------

See end of section for complete selection of cutters.

Exacta

Appropriately named, Exacta machines make keys exactly like factory originals. Hand operated with no pattern key needed, the Exacta originates keys by code to factory depths and spacing.

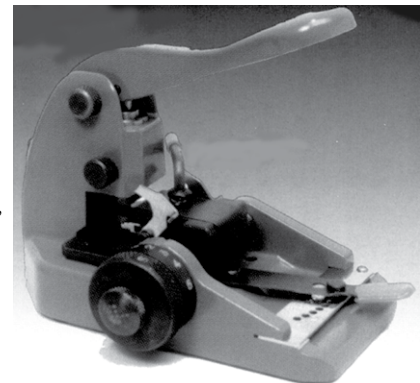

**MK3 is engineered for
Kwikset/Titan® keys.**

Order #	Item #	Price
400-3203	MK3	\$1220.60

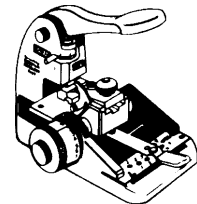



The Ultracode is an innovative electronic code-cutting/key duplicating machine.

The Most Rugged, Reliable, & Precise Electronic Code Cutting Machine

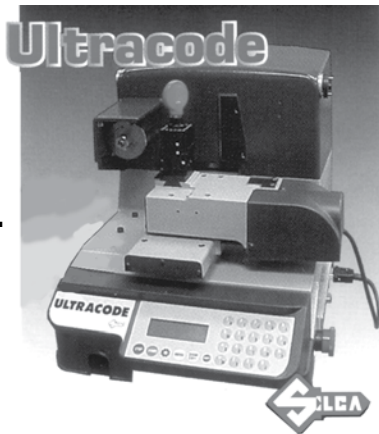

The Ultracode is an electronic key cutting machine for code cutting cylindrical automotive, and flat keys. This revolutionary machine works stand alone or connected to a personal computer, and meets the demand of today's professional key cutting centers.

- Includes Optical Reader for Dey Duplication.
- Pre-loaded with 1300 depth and spacing tables. Up to 180 user defined tables can be added.
- Popular North American and International Automotive Code Series are pre-loaded into the Ultracode's database.
- Wide range of lock systems can be cut on the Ultracode.
- Allows Code Cutting when used stand alone or with a PC and optional software.

(Runs with Locksmith Ledger Computext® code software - for purchase information contact the Locksmith Publishing Corporation))

- **Cutter motor:** Single phase and speed - 110V, 60Hz
- **Diagnostics:** Incorporated in the machine's internal program
- **Two axes:** X=spaces; Y=depths
- **Carriage Movements:** On roller guides, controlled by step motors and sensors
- **Clamp:** Four sides
- **Calibration:** By means of an electromechanical device
- **Dimensions:** 19.7" Wide, 19.7" Deep, 16.5" High
- **Weight:** 81.4 lbs (37 kg)
- Made in Italy

Order #	Item #	Catalog Price
400-6080	Ultracode	\$13,086.00



Blue Punch Key Machine

Heavy Duty and Built to Last.

Dedicated key punch machine designed to provide factory original keys. Creates keys with the speed of a duplicator. Fast, extremely accurate and easy to use. Set up at the factory to provide automatic spacing and depth.

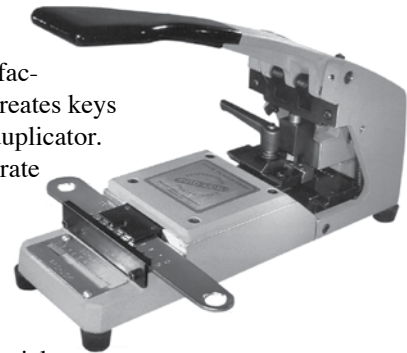

An ideal key machine for the commercial locksmith, hotels, schools, and other institutions. Precision machined to the tightest tolerances. Portable and dependable, hand operated - no electrical outlet needed. The professionals clear choice: The FASTEST and EASIEST punch machine on the market.

Dedicated Punch Machines.

Designed to cut "factory original" keys by code. Automatic spacing and depth. (Formerly sold as Keymak & Armbruster.)

Order #	Item	Catalog Price
441-1020	BP 201 SC Schlage Classic Kwy	\$2050.00
441-1040	BP201KW Standard Kwikset	2050.00

A2 Standard Interchangeable Core.

Order #	Item #	Catalog Price
441-1030	BP201 IC	\$2050.00



BP-CASE BluePunch Case



Key Machine Case
Designed in hard plastic with a handy handle.
Heavy Duty Carrying Case.

Order #	Item #	Dealer Price
441-1000	BP-CASE	\$130.00



Rytan. RY100 Semi-Automatic

Carriage travel in excess of 1-5/8". Capable of cutting longest cylinder keys.

High speed "stick shift" action.

Uniform clamping machinist grade key vices.

Full function shoulder/tip guage. Extended travel means one guage does it all... no problems calibrating space adjustments for shoulder and tip. Use of inserts or adaptors for tip guaging is eliminated.

Oversize 3/16" diameter wing nut studs and radial needle thrust bearings.

Slotted top vices are easily reversed without removing wing nuts.

Order #: 723-0100	\$1890.00
--------------------------	------------------

RY100-30 Standard cutter for cylinder and auto keys. Key Cutters

Order #: 723-1003	\$ 276.00
--------------------------	------------------

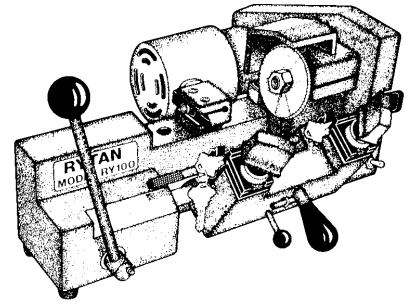

Carriage driven by heavy duty steel links.
• Brush not included

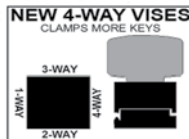
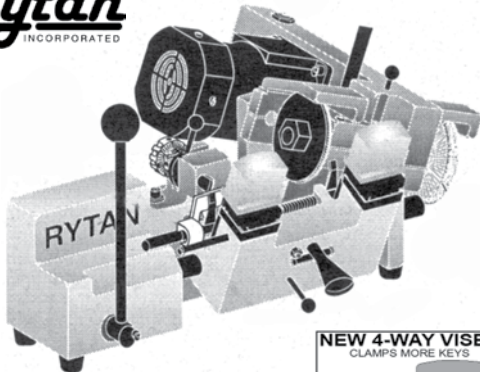

RY456 Semi-Automatic High Speed Key Duplicating Machine with Medeco key Cutting Capability, with 4-Way Jaws

Adjustable Stylus Included.

.0005" Accurate

Key Gauge Protector Included

Same as the RY256 but with a NEW CARRIAGE, NEW 4-WAY VISES, NEW CUTTER and Adjustable Stylus

Order #	Item #	Catalog Price
723-0456	RY456	\$2598.00

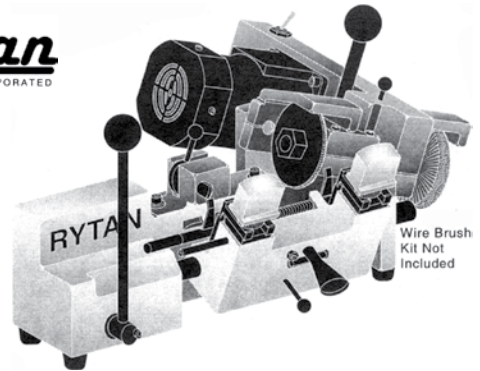

Wire Brush Kit Not Included

RY256 Original Semi-Automatic High Speed Key Duplicating Machine with Medeco Key Cutting Capability

Duplicate standard cylinder keys, automotive keys and Medeco keys on this versatile machine.

"Stick-Shift" key cutting action cuts keys smooth and accurate.

Built-in cutter shaft lock, large diameter key cutter, quick-change step vise jaws, heavy-duty ball bearing motor, and wide spaced vise jaws to hold large headed keys.

- Cut Medeco without changing Cutter or Vises
- Quick Change top vise jaws
- Built-In Full Function key gauging

Top shoulder gauge standard keys

Top gauge keys such as Ford

Behind the tip such as Best & Falcon

(wire brush kit not included)

Order #	Item #	Catalog Price
723-0256	RY256	\$2516.00

RYTAN

Rytan
INCORPORATED

- Popular Built-in Full Function key gauging
- Top shoulder gauge standard keys
- Tip gauge keys such as Ford
- Behind the tip such as Best & Falcon
- Do it all with Rytan's exclusive built-in key gauge!

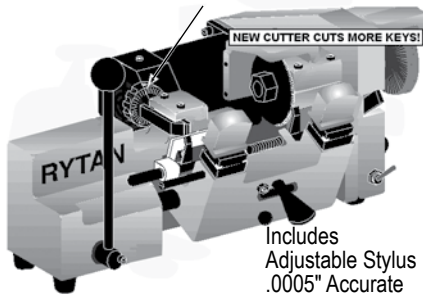

• Brush not included

Rytan. RY200 Universal Key Duplicating Machine with 4-Way Jaws

Same as the famous RY100 machine with a new carriage, new 4-way vises, new cutter, and adjustable stylus.

- Universal 4-Way Vise Jaws clamps more keys
- New Cutter cuts more keys, like Titan, GM, and Chicago in addition to everything else.
- Built-in Cutter Shaft Lock
- Heavy Duty All Ball Bearing Motor
- Wide Spaced Vises for Large Keys
- First Time Ever - Easy to Replace 4-Way Jaws, Replacement Cartridges - Just Drop them in.

Order #	Item #	Catalog Price
723-0200	RY200 115VAC	\$2310.00

ILCO Key Machine Parts

ILCO Thrust Bearings.

Use on all Ilco machines equipped with reversible vises.

400-2025	IND 1-59	\$13.80
----------	----------	---------

ILCO Drive Belt,

3" diameter "O" ring type. IND-190-16

400-1999	IND 190-16	\$9.80
----------	------------	--------

ILCO Cutter Conversion Kits

Kit # 849-00-51 contains P-X23MC titanium nitride coated milling cutter, cutter guides & two different spacers. Replaces the 34MC milling cutter.

Order #:	400-2849 (U)	\$143.10
----------	--------------	----------

ILCO/Parts

ILCO Key Machine Parts

Super Jaws

Specially designed & precision engineered reversible vises securely grip double sided keys by millings, instead of blade. Keys such as Mazda MZ17, GM B68 and VW X9 are held firmly while cutting first side as well as "hard-to-hold" second side.

Two Super Jaw vises available and are currently being supplied on all new ILCO machines.

Super Jaw will hold double sided keys by the tip or bottom milling as needed.

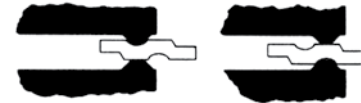
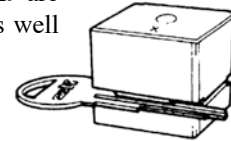
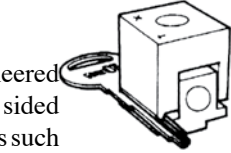

SUPER JAW-1

Can be retrofit on the following models:

ILCO 008, 017, 018, 010, 016, 2184CV & 2585DU.

400-2018	Super Jaw-1	\$116.90 pair
----------	-------------	---------------

SUPER JAW-2

Can be retrofit on the following models: ILCO 023, 024, 025, 026. Dominion 132AM, 143M, 144M, 145M, 147M, 150AM. Taylor KD6, KD60, KD70.

400-2019	Super Jaw-2	\$110.20 pair
----------	-------------	---------------

Deburring Brushes

ILCO Soft-Touch Super Brush fits all Ilco machines equipped with wire brushes. Safer, lasts longer than conventional wire brushes.

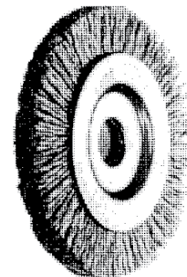

3" diameter,	Order #: 400-2030	\$22.00
6" diameter,	Order #: 400-2031	52.20

HPC TYX-3

3" Diameter Soft brush,

Order #: 360-0502 \$23.78

HPC

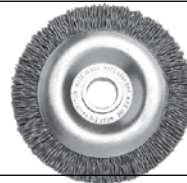

Rytan

RYT-100-101 Nylon bristles, brush kit.

Fits all RY100 & RY256 machines.

Order #:	723-1010 RYT-100-101	\$89.50
----------	----------------------	---------

HPC Key Machine Parts



**Horseshoe
Tip Stop**

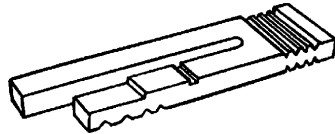

For use with 7 pin Best and 10 cut Ford on all 1200 Series Machines.

360-1054	HPC CM-1054R	\$23.78
----------	--------------	---------



Thrust Bearings

BBW-2. Set of 2 ball bearing units & 4 hardened steel washers for machine wing nut studs.

Order #: 360-0028	BBW-2	\$17.34/set
-------------------	-------	-------------

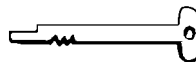

Key Vice Index

CW1054MA. all 1200 Series Machines

Order #: 360-0052	CW 1054MA	\$9.98
-------------------	-----------	--------

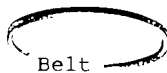

Belt

For Blitz, CodeMax, 3333 & 6666

Order #: 360-0053	CM-1083MA	\$38.46
-------------------	-----------	---------



Ford Blocks

FB-1. Set of 2 blocks for holding Ford double-sided keys when duplicating.

Order #: 360-0147	FB-1	\$20.88/pair
-------------------	------	--------------

**DON'T SEE WHAT YOU
NEED? GIVE US A CALL!**

**HPC Replacement
Wing Nut**

Blue, fits all HPC key machines except Laserpoint.



360-1100	HPC-SNK-3	\$19.38
----------	-----------	---------



Slotter Cutters

for safe deposit key cutting

such as Mosler, S & G, Yale, Diebold and many more! These cutters are made of high quality carbide and work great with your HPC 1200 Series key machine. Cutters are 2.375" in diameter, with .375" diameter hole.

Order #	Item	Thickness For	PRICE
360-1151	CW-BC	.054 Yale	\$211.90
360-1152	CW-CC	.058 S & G, Yale, Lloyd Matheson	211.90
360-1153	CW-DC	.064 S & G	215.90
360-1154	CW-EC	.069 Diebold	225.90
360-1155	CW-FC	.088 for Mosler	257.90



**Conversion
Double Angle
Cutter**

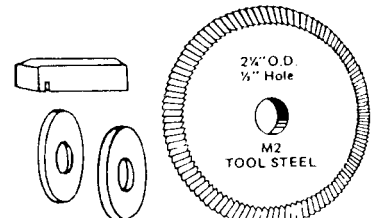

Cut from depth keys or duplicate. M2 Tool Steel

Key Cutters

cutter, cuts steel, brass or nickel silver. Fits the following: HPC Speedex, Taylor KD1, 2 etc., Dominion 145, 146, Ilco 2584, 2585, Keil 4, 4-1/2, Curtis 2H. Replaces the following single angle cutters: 23RF, 26, CU-5, CU-1, 23MC, and 34MC. Set includes cutter copy dog, washers and complete instructions.

Order #	Item #	Price
360-0108	CW-51MC	\$207.00

KEY CUTTERS

Key Cutters

KEY CUTTERS

Key Cutters

Parts

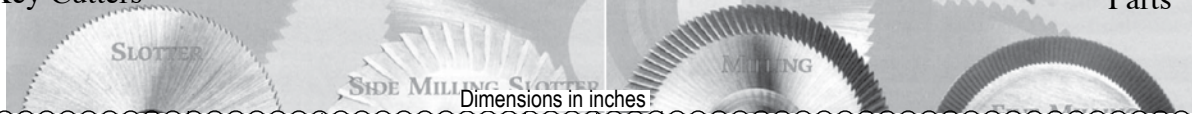

Dimensions in inches

Order #	Item #	Type	Material	Dia"	Thick	Hole	Machines	Price
865-8005	CU5	Milling	T.S.	2.250	.250	.500	Taylor KD1, KD5, KD6, KD20; Various Curtis	90.30
400-2057	P9MC	Milling	T.S.	2.875	.206	.500	Ilco 016, 017, 018	192.30
400-2049	(U) 10MC	Milling	H.S.S.	2.750	.280	.875	DL125A,128AM, 128SM, 130AM,132AM,150AM	232.40
400-2050	11MC	Milling	H.S.S.	2.250	.290	.500	DL144M, 144MA; Ilco 024; Taylor 144MT-A	205.40
360-0090	14MC	Milling	T.S.	2.375	.375	.375	100° Angle, 1200 Series Machines	190.90
400-2056	T14MC	Milling	T.S.	2.375	.375	.375	100° Angle, 1200 Series Machines	190.90
360-0092	CW-16	Flat Slotter		2.250	.045	.500	HPC Speedex 9160, 9180	99.00
400-2059	16C	End Mill	H.S.S.	0.187	-	-	ILCO 009; Taylor KD90, KD30	85.10
400-2063	19MC	Milling	H.S.S.	2.875	.281	.500	Ilco 2183DM, HM, 010-006; Keil1, 1-1/2, 10	123.40
400-2190	P19MC	Same as 19MC, but Titanium Nitride coated for extra life.						163.30
400-3124	CU20	Milling	H.S.S.	2.237	.250	.500	Ilco 020, 040, 024A, 024B, 044	95.30
360-0095	CW20FM	Milling	T.S.	2.375	.375	.375	HPC 1200 Series 76° Angle for Sargent	193.00
400-2064	20MC	Milling	H.S.S.	2.375	.375	.375	Ilco 2178U,2178UA, 2178UC, 178U	190.40
360-0096	23MC	Milling	H.S.S.	2.375	.093	.500	HPC 9160, 9180; Ilco 025, 045	150.00
400-2058	PX23MC	Milling	"P"	2.375	.093	.500	DL143M, 145M; Taylor 145MT-A; Ilco 025, 045	154.90
360-0098	CW23RM	Fine Milling	T.S.	2.250	.250	.500	Replacement for Ilco 9120RM	95.00
400-2066	23RF	Fine Milling	T.S.	2.250	.250	.500	Ilco 2184CD, H2584CV, 2585DU, 008, 190; DL145, 145M, 147, 149M; HPC 9100, 9110; Taylor KD1, KD5, KD20; Keil 4-1/2, 12-1/2, 13-1/2, 15; Curtis 2000	64.60
400-2068	CW-27	Slotter	H.S.S.	2.250	.045	.500	Ilco 2184CD, H2584CV; DL146, 146M; HPC 9100, 9110; Taylor KD1; KEIL 4-1/2, 12-1/2	62.40
400-2070	CW-27-2	Slotter	H.S.S.	2.375	.030	.500	Ilco 2585DU; Keil 15-1/2	60.40
400-2074	34MC	Milling	H.S.S.	2.250	.250	.500	Ilco 2585DU, H2584CV, 2184CD; Keil 4-1/2, 12-1/2, 13-1/2, 15; Cole 1000, 3000, 5000	95.30
400-2195	P34MC	Same as 34MC, but Titanium Nitride coated for extra life.						158.10
400-2076	37MC	Milling	H.S.S.	2.250	.200	.500	Ilco 2184CD, 2585DU; HPC 9100, 9110; DL135, 135M, 145, 145M, Taylor KD5	250.00
360-0105	41HQC	Carbide Mill	C.	2.500	.281	.375	HPC 3333, 6666, 1250, 1350	671.70
360-2325	42HQT	Tool Steel	T.S.	2.500	.281	.375	HPC 3333, 6666	199.90
360-0106	45SMS	Side Milling Slotter	H.S.S.	2.375	.045	.500	Ilco 2585SMS, 2584SMS, 2184CD, HPC 9110; Keil 12S, 12-1/2S, 15S, 15-1/2S	139.90
400-2078	SMS 45	Side Milling Slotter	H.S.S.	2.375	.045	.500	Ilco 2585SMS, H2584SMS, 2184CD; HPC 9110, Keil 12S, 12-1/2S, 15S, 15-1/2S	129.90
190-1647	CW47MC	Tool steel	T.S.	2.395	.250	.375	HPC 1200 Series for some automotive	226.00
400-2039	CU50A	Milling	C.	3.150	.197	.630	Rigel KD50A, KD71A, KD50C; Ilco Bravo II	255.10
360-0112	90MC	Milling Cutter	T.S.	2.375	.375	.375	HPC 1200 Series (90° angle, Best, Falcon, Eagle, Arrow, Kaba, and IC core.	199.90
360-0113	CW-1011	Tool Mill Steel	T.S.	2.375	.250	.375	HPC 1200 Series 90° angle, small cyl. cutter	190.90
360-0114	CW-1012	Tool Mill Steel	T.S.	2.375	.375	.375	HPC 1200 Series for cutting Medeco	190.50
360-0115	CW-1013	Tool Mill Steel	T.S.	2.375	.375	.375	HPC 1200 Series (Emhart High Security)	282.00
750-1174	22-01	Solid Carbide End Mill		0.188			For All HPC/Scotsman Tubular Mchines	72.00

• H.S.S.: High Speed Steel • T.S.: Tool Steel • C: Cobalt • Prefix "P": Titanium Nitride coated for extra life

- Slotter.** Designed to cut flat steel and safe deposit keys.
- Side Milling Slotter.** Designed to cut flat steel and safe deposit keys. This cutter has teeth along its sides so the key machine can widen cuts with a side to side cutting motion.
- Milling.** The teeth on a milling cutter are formed using a grinding or milling machine operation on the basic cutter blank.
- Fine Milling.** Fine milling cutters are manufactured using the same technique for milling cutters. They feature fine, closely spaced teeth, a smooth cutting action, and greater service life compared to the rotary file-type cutter.
- End Mill.** When used on certain machines, an end mill cutter can mill grooves in keys, or make curved cuts on tubular keys.

Some cutters above are supplied by various manufacturers, according to availability.